

## Energiser Installation Guide

### For Dry Battery Powered Energisers

*Thank you for purchasing a Rutland energiser. This guide provides instruction to properly install, operate and maintain your unit, ensuring the most effective performance.*



**ESB15**



**ESB25**



**ESB117(T)**



**ESB122(T)**

**ESB127(T)**

**ESB137(T)**

## Before You Start

### **Installation of Energiser and Fence**

Electric fences should be installed and operated so that they cause no danger to persons, animals or surroundings and as far as is reasonably practicable, they are out of reach of children and not subject to mechanical damage. Never connect more than one energiser to the same single or multi-wire fence. Any other fence systems powered by a different energiser should be at least 2.5 metres apart. If this gap is to be closed, use non-conductive material or an isolated metal barrier. Any electric fence or part thereof installed along a public road or pathway should be identified by



warning signs at regular intervals. The warning sign should have a yellow background and be at least 100 mm x 200 mm. The words "Caution Electric Fence" or symbol should appear in black, permanent marking on both sides of the sign and be at least 25mm in height.

- Barbed wire must not be electrified.
- If an electric fence has to be installed in the vicinity of overhead power lines it should not cross above it or run in parallel to it for any great distance. If it is necessary to pass under overhead powerlines it should be done at right angles and the vertical distance between any fence wire and the surface of the earth should not exceed two metres.
- If an electric fence has to be installed near any communication lines, the distance from the lines and the fence or any part of it should be more than two metres.
- If the energiser is installed in the vicinity of any building, care must be taken to ensure that the earth for the electric fence is more than 10 metres away from any domestic electricity board earth or telecommunications system earth.
- Follow the manufacturer's directions for proper earthing of your electric fence.
- Use insulated cable for connecting leads that run inside buildings or underground. Take care to avoid damage from animal hooves or vehicle tyres and use a conduit of insulating material if needed.
- Do not install connecting leads in the same conduit as the mains supply wiring, communication cables or data cables.
- Low output energisers provide satisfactory and safe performance for deterring birds, household pets and training animals such as cows.
- If the electric fence is intended to deter birds from roosting on buildings, do not connect the fence wire to the earth terminal. Use a warning sign at any point where a person may access the fence wire.

### **Manufacture Standard**

Built to Comply with CE, IPX4, EN60355-2-76  
Health & Safety Standards, EN55014, EMC

### **Safety**

- Keep combustible materials away from the connection to the fence energiser.
- If the supply cord is damaged, it must be replaced by the manufacturer, its service agent or similarly qualified person in order to avoid a hazard.

**Warning:** Avoid touching electric fence wires, especially with the head, neck or torso. Do not climb over, through or under multi-wire electric fence. Use a gate or a specially designed crossing point. Incorporate a non-electrified gate or crossing stile where an electric fence crosses a public pathway. At any such crossing the adjacent electric fence should carry warning signs.

### **Tools Required**

- Flathead and Phillips screwdrivers

### **Other Required Components**

- Earth stake(s) (part no. 18-179B; includes line clamp)

## **How Electric Fencing Works**

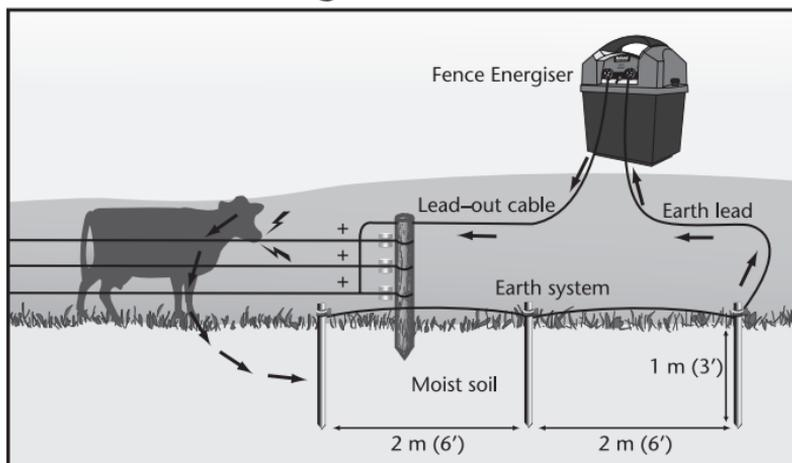

# Energiser Installation

## STEP 1: Mount Energiser

**IMPORTANT:** *Energisers must be kept off ground*

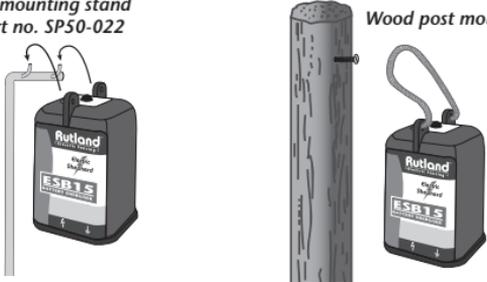
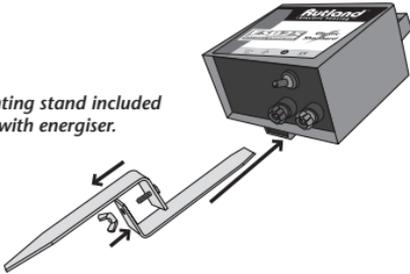
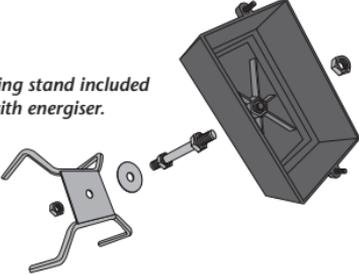
Model	Mounting
<b>ESB15</b>	<p data-bbox="288 397 453 442"><i>Use mounting stand part no. SP50-022</i></p> <p data-bbox="681 412 861 434"><i>Wood post mounting</i></p> 
<b>ESB25</b>	<p data-bbox="311 802 522 842"><i>Mounting stand included with energiser.</i></p> 
<b>ESB117(T)</b> <b>ESB122(T)</b> <b>ESB127(T)</b> <b>ESB137(T)</b>	<p data-bbox="332 1110 542 1150"><i>Mounting stand included with energiser.</i></p> 

## STEP 2: Connect EARTH and FENCE Terminals

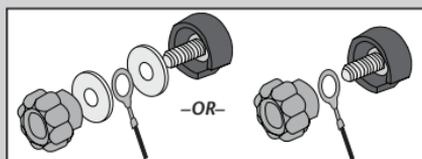

Place ring end of crocodile clip over terminal. Connect GREEN/YELLOW wire to EARTH terminal; connect RED wire to FENCE terminal.

Model	Connect EARTH	Connect FENCE
ESB15		
ESB25		
ESB117(T) ESB122(T) ESB127(T) ESB137(T)		

### STEP 3: Connect Earth System

Connect green crocodile clip to earth stake (part no. 18-179B)

*NOTE: Connect additional earth stakes with lead-out cable if required*

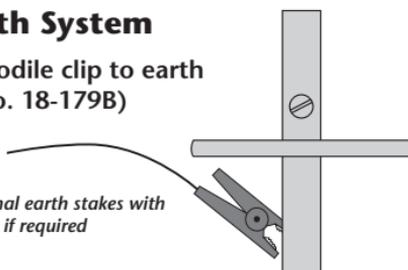

### Ensure Earth System is Sound

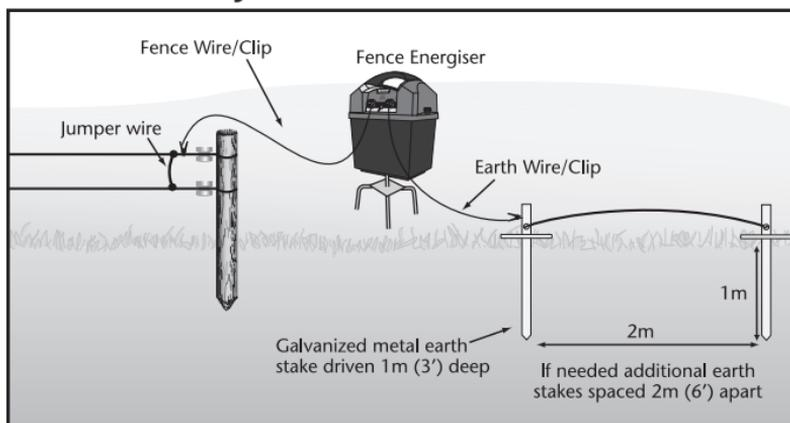

### STEP 4: Connect Fence Lead Cable to Fence Line

Connect red crocodile clip to fence line

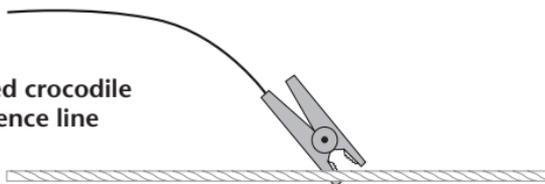

### Ensure Fence System is Sound

- Ensure all connection points such as joiners, and insulators are sound and secure
- IMPROPER CONNECTION POINTS WILL AFFECT YOUR ENERGISER PERFORMANCE

## STEP 5: Connect to Battery (Model ESB15)

**NOTE:** Make sure power switch is in OFF (0) position.

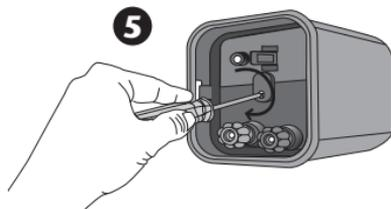
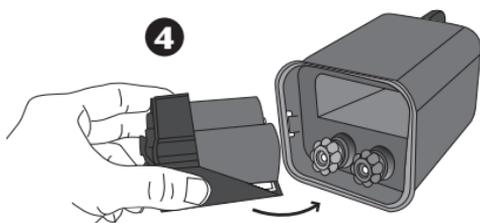
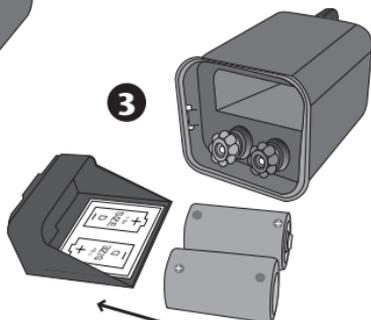
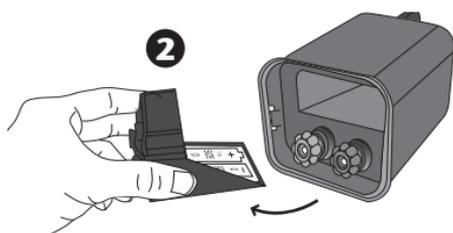
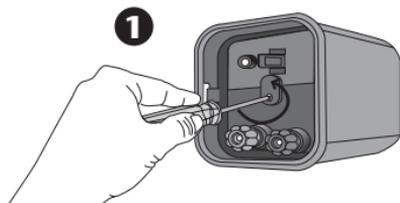
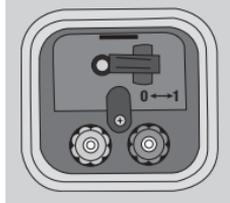

## STEP 5: Connect to Battery

### Model ESB25

**NOTE:** Make sure power switch is in OFF (0) position.

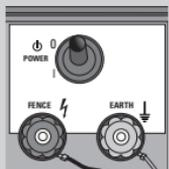

**1**

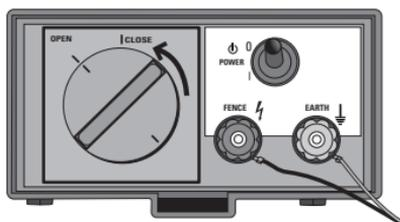

**2**

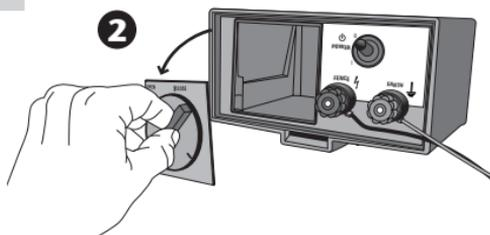

**3**

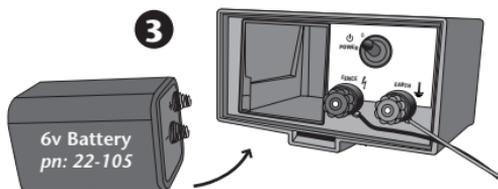

**4**

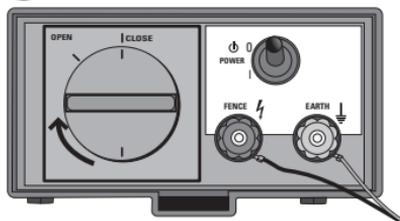



## STEP 5: Connect to Battery

### Models ESB117(T)

**NOTE:** On models with toggle switch, ensure power switch is in OFF (0) position.

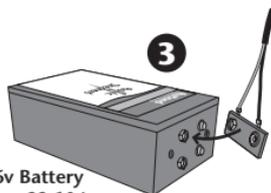
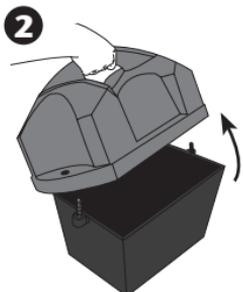
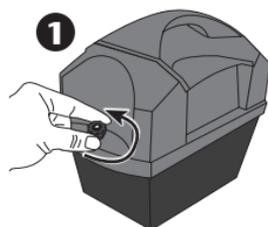

6v Battery  
pn: 22-104  
or 22-106

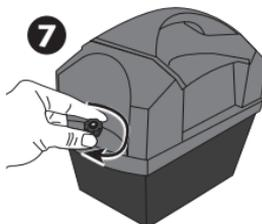
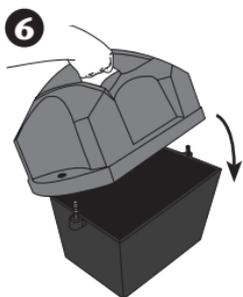
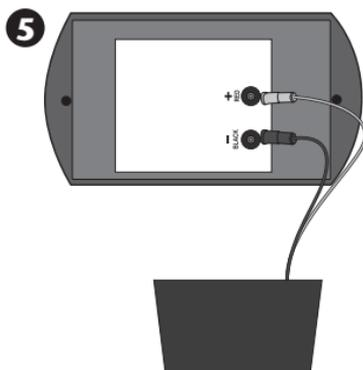

## STEP 5: Connect Battery

Models ESB122(T), ESB127(T), ESB137(T)

**NOTE:** On models with toggle switch, ensure power switch is in OFF (0) position.

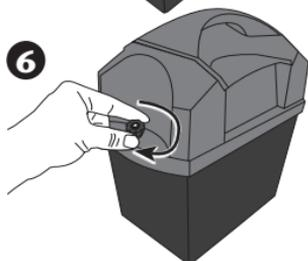
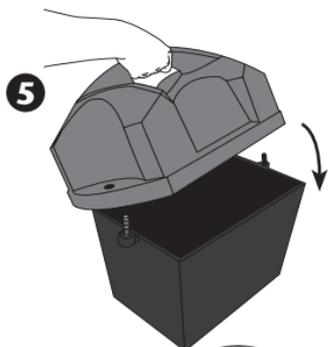
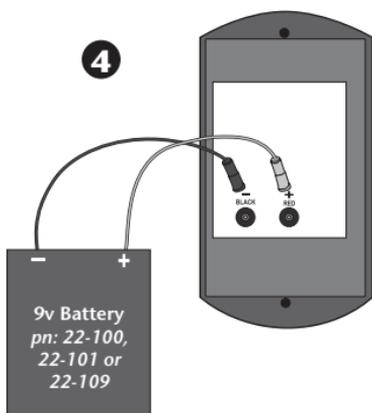
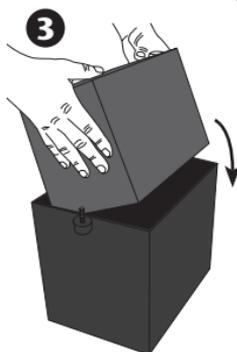
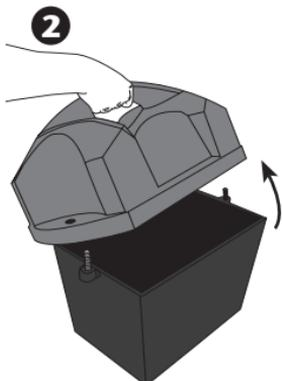
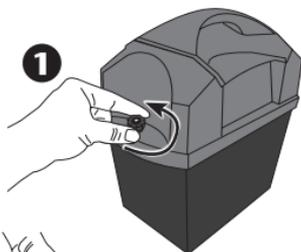

# Energiser Operation

For Model: ESB15

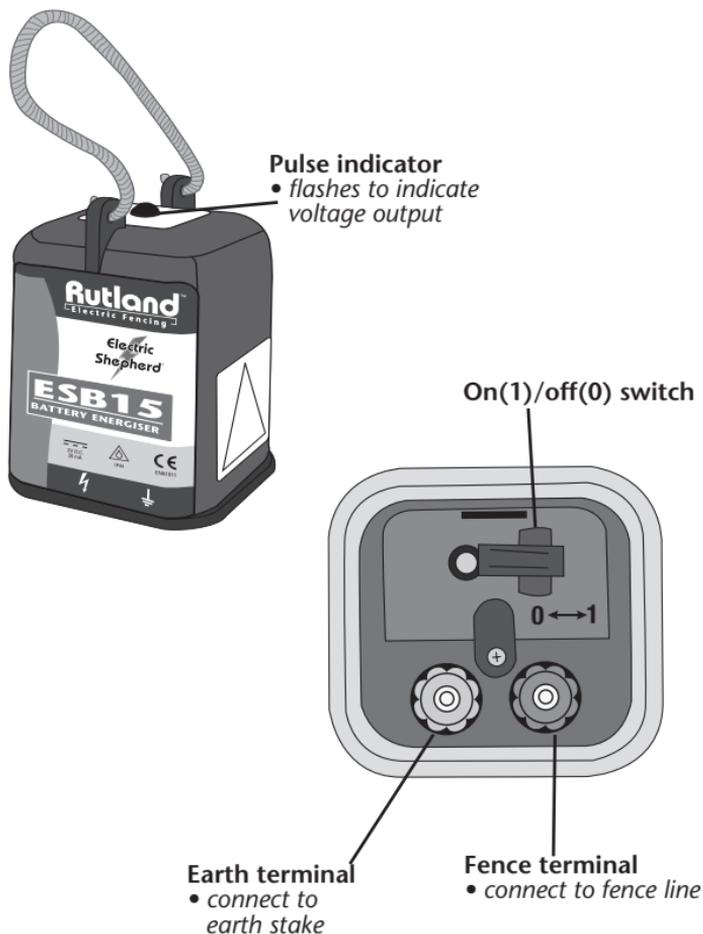

Model	Approximate Battery Life
ESB15	35 days

# Energiser Operation

For Model: ESB25

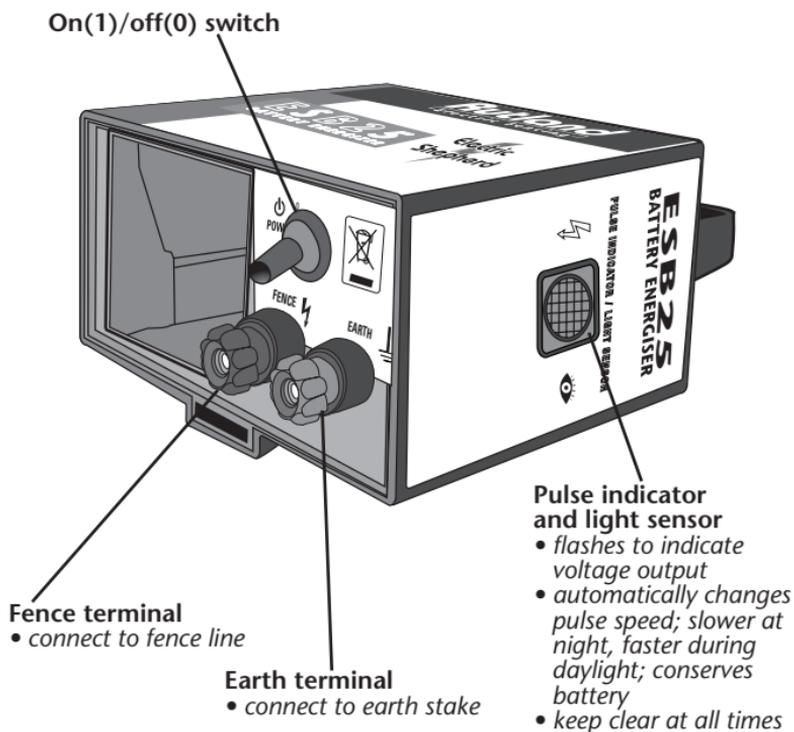

Model	Approximate Battery Life
ESB25	94 days

# Energiser Operation

For Models: ESB117, ESB122, ESB127, ESB137



**Pulse indicator**  
• flashes to indicate voltage output

**Earth terminal**  
• connect to earth stake

**Fence terminal**  
• connect to fence line

**Battery low indicator**  
• flashes if battery needs replacing

**Light sensor (not on ESB122)**  
• keep clear at all times

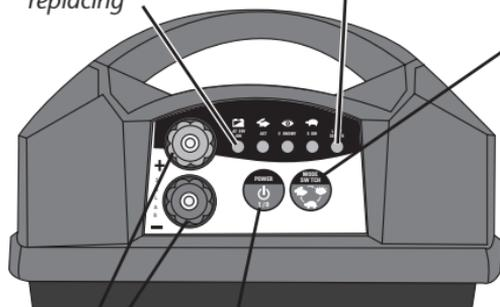

**Fast/economy/slow switch (not on ESB122)**

**Fast pulse:**  
• use for training stock

**Night econ pulse:**  
• automatically changes pulse speed; slower at night, faster during daylight; conserves battery

**On(1)/off(0) switch**  
• press and hold for one to two seconds

**Slow pulse:**  
• use to conserve battery power after stock are used to fence

**ESB137 only—terminals for optional solar assist panel**

Model	Approximate Battery Life
ESB117	119 days
ESB122	260 days
ESB127	197 days
ESB137	98 days

# Energiser Operation

For Models: ESB117T, ESB122T, ESB127T, ESB137T

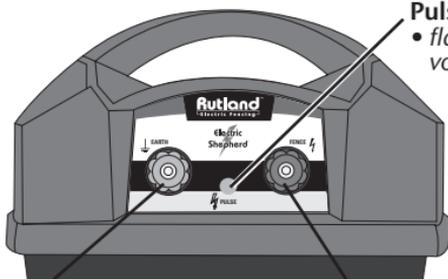

**Pulse indicator**

- flashes to indicate voltage output

**Earth terminal**

- connect to earth stake

**Fence terminal**

- connect to fence line

**Battery low indicator**

- flashes if battery needs replacing

**Fast/economy/  
slow switch  
(not on ESB122T)**

**Fast pulse:**

- use for training stock

**Night econ pulse:**

- automatically changes pulse speed; slower at night, faster during daylight; conserves battery

**Slow pulse:**

- use to conserve battery power after stock are used to fence

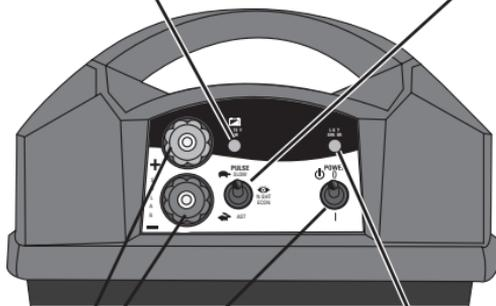

**On(1)/off(0) switch**

**Light sensor (not on ESB122T)**

- keep clear at all times

**ESB137T only—terminals for optional solar assist panel**

Model	Approximate Battery Life
ESB117T	119 days
ESB122T	260 days
ESB127T	197 days
ESB137T	98 days

# Maintenance/Testing

## Fence Line Maintenance

- Regularly test voltage at the furthest point on the fence line from the energiser – we recommend Rutland Digital Tester 14-172 or 8-Light Tester 14-173
- Routinely check all fence and earth connections to ensure they are sound
- For best performance, keep fence line free of vegetation
- Keep insulators free from dirt, dust and cobwebs

## How To Test Fence

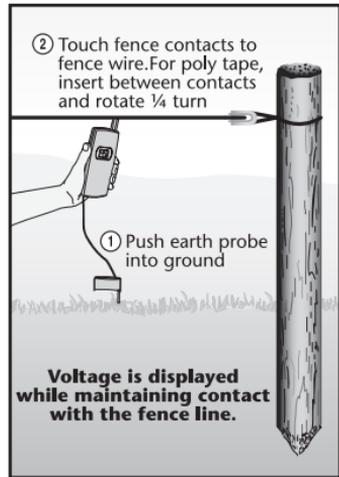

## How To Test Earthing

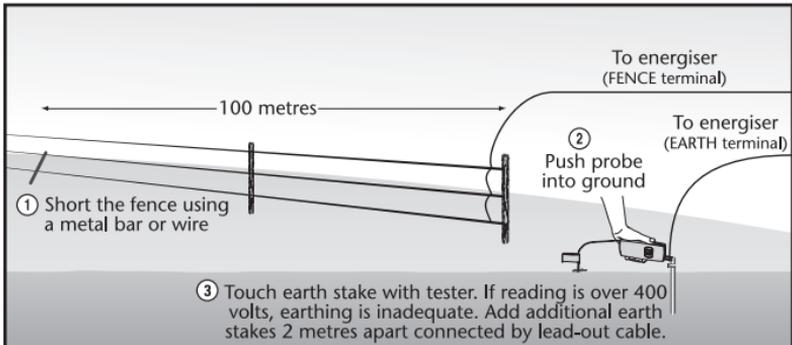

## Energiser Troubleshooting

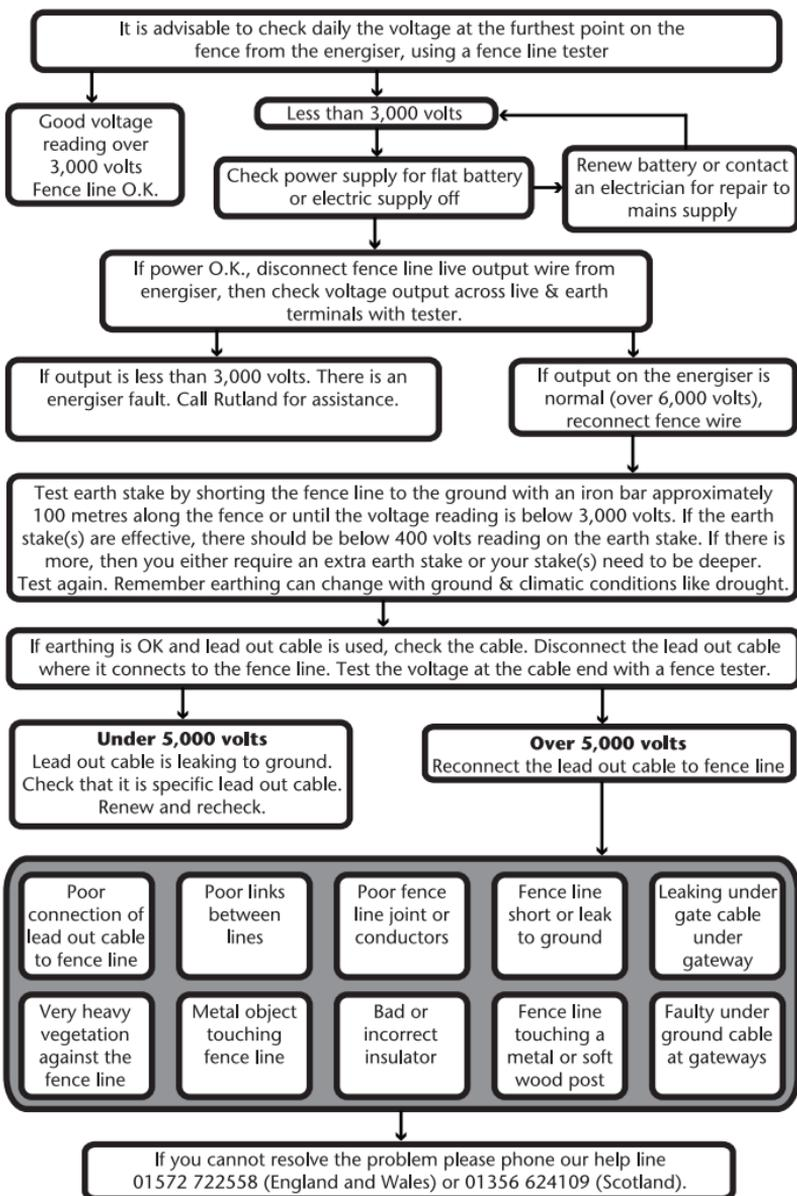



## Warranty

This energiser is warranted to be free from manufacturing defects for two years from the date of purchase by the end user. Proof of purchase is required for warranty consideration. If no sales receipt is available, the date of manufacture will be used to determine the warranty period.

The warranty does not apply to any defect in the product caused by improper installation, misuse, tampering, neglect, moisture or any other reason not related to defects in material or workmanship of the product.

Warranties are not assignable or transferable. It is for the benefit of and given only to the first consumer purchaser of the product, and shall not be for the benefit of nor given to any subsequent owners or any other user or to any person.

The obligation of Rutland Electric Fencing Co. Ltd. under warranty is limited only to repairing or replacing, at its discretion, any part of the product that is defective and is covered by the terms of this warranty. If any covered defect occurs during the warranty, return the product to the retailer for rectification who will either undertake the repair or forward the energiser to ourselves. In no case shall Rutland Electric Fencing Co. Ltd. be liable for incidental, consequential, third party, special or indirect damages of any kind.

## LIMITATION OF DAMAGES

The directions for use of this product should be followed carefully. It is impossible to eliminate all risk inherently associated with use of the product. The effectiveness of Rutland brands of fence energisers may depend on the effectiveness of connections, interruption of power source, accidental shorting of wires, weather conditions, or the manner of use or application, all of which are beyond the control of Rutland Electric Fencing Co. Ltd. or the seller. The buyer shall assume all such risks.

Rutland Electric Fencing Co. Ltd. warrants that this product is fit for the purposes for which it was designed and referred to in the directions for use, subject to the inherent risks referred to above. Rutland Electric Fencing Co. Ltd. makes no other expressed or implied warranty of fitness or merchantability or any other expressed or implied warranty. IN NO CASE SHALL RUTLAND ELECTRIC FENCING CO. LTD., OR THE SELLER, BE LIABLE FOR CONSEQUENTIAL, SPECIAL OR INDIRECT DAMAGES RESULTING FROM THE USE OR HANDLING OF THIS PRODUCT. RUTLAND ELECTRIC FENCING CO. LTD. AND THE RETAILER OFFER THIS PRODUCT, AND THE BUYER AND USER ACCEPT IT, SUBJECT TO THE FOREGOING CONDITIONS OF SALE AND WARRANTY WHICH MAY BE VARIED ONLY BY AGREEMENT IN WRITING SIGNED BY AN AUTHORIZED OFFICER OF RUTLAND ELECTRIC FENCING CO. LTD.

## SAVE THIS INSTALLATION AND USERS MANUAL



**WEEE (Waste Electrical & Electronic Equipment directive)** This instruction applies to any product which displays the bin symbol on it or its packaging. If your electrical product is beyond repair and you wish to dispose of it please **DO NOT** dispose of it with your normal household waste. Either return it to your point of purchase (retailer) for collection by Rutland Electric Fencing or take to any authorised recycling centre. Your local council/ authority will have information available. This notice refers only to products manufactured or distributed by Rutland Electric Fencing Co. Ltd.

**Rutland**<sup>TM</sup>  
Electric Fencing

*Please visit our website for further installation tips,  
product manuals and additional electric fencing information:*

**[www.Rutland-Electric-Fencing.co.uk](http://www.Rutland-Electric-Fencing.co.uk)**

*To request a Rutland Electric Fencing Co Ltd. catalogue or  
for information on any Rutland product, please contact us at:*

**Rutland Electric Fencing Co Ltd.**

Fencing House  
8 Lands End Way  
Oakham, Rutland  
LE15 6RF UK

Email: [Enquiries@Rutland-Electric-Fencing.co.uk](mailto:Enquiries@Rutland-Electric-Fencing.co.uk)

Phone: (44) 0 1572 722558 – UK and EU  
(44) 0 1356 624109 – Scotland  
(44) 0 7817 396776 – N. Ireland