

KERBL Pet

#84867

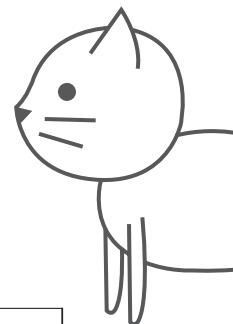

A M3.5X30 64+2pcs	1 	2 	3 	4
B M4X20 24+2pcs	6pcs	18pcs	1pc	2pcs
C M3X14 16+2pcs	5 	6 	7 	8
D M5X30 4+1pcs	6pcs	1pc	2pcs	2pcs
E M5X40 1pc	9 	10 	11 	12
F 4pcs	G 4pcs	2pcs	2pcs	1pc

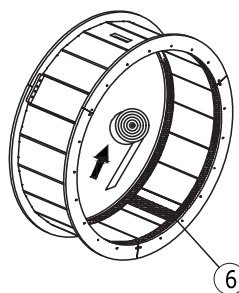
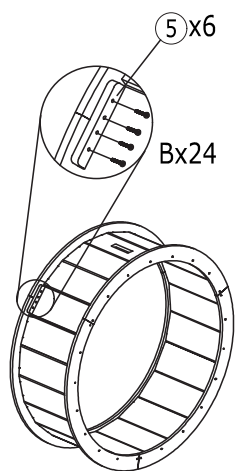
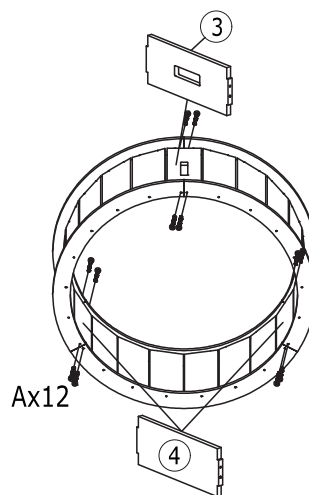
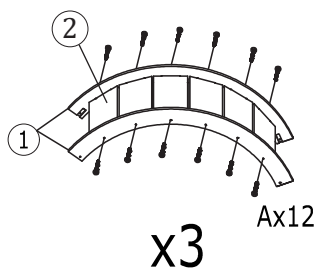

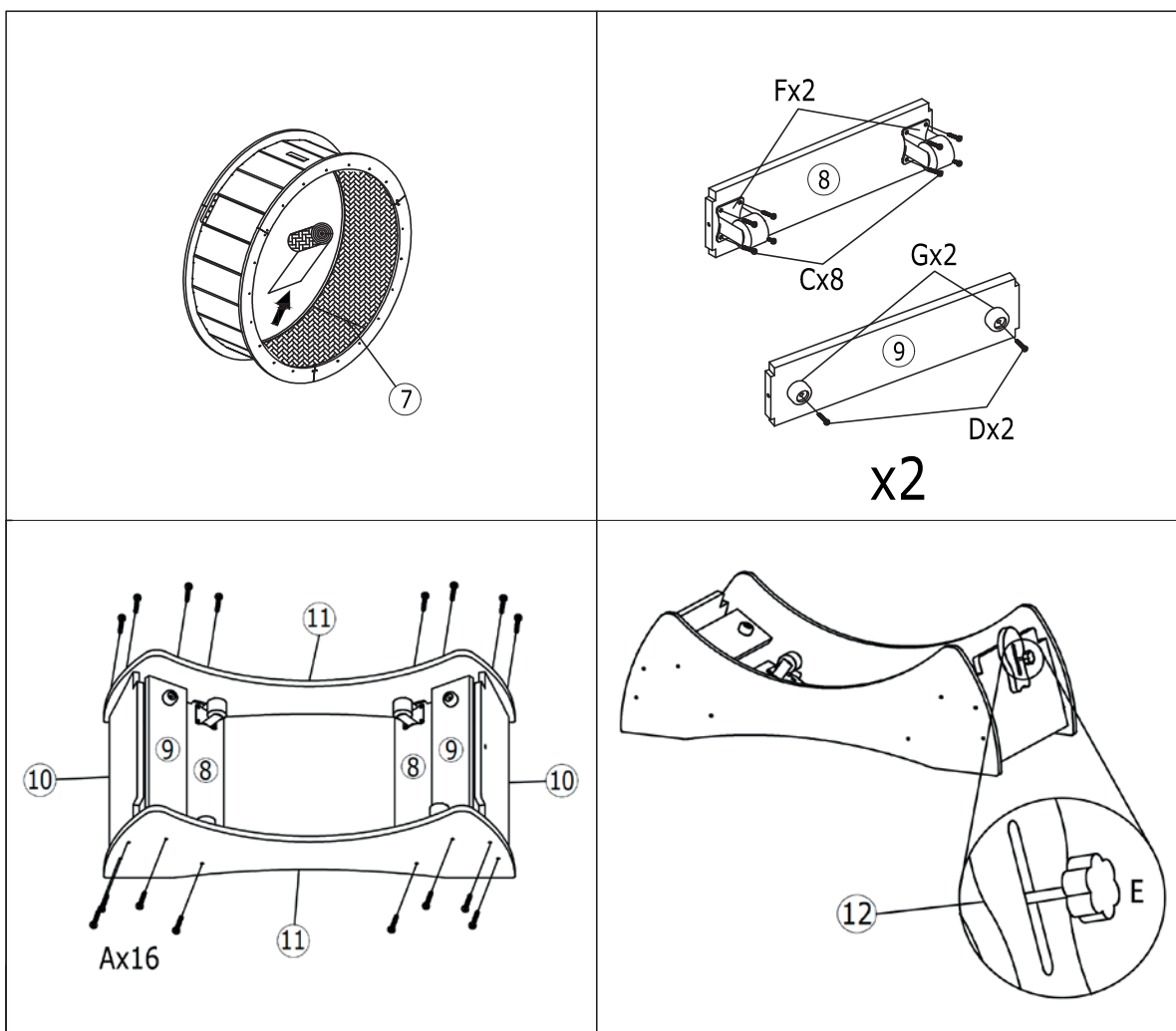
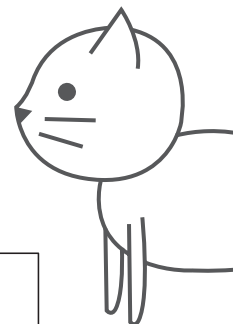
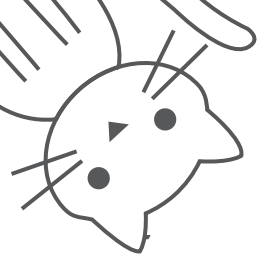

Aufbauvideo
Assembly Video
Vidéo de montage

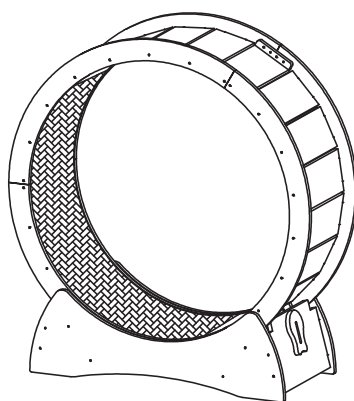

(DE) Bitte halten Sie die Reihenfolge der Arbeitsschritte 1,2,3,... von der Skizze ein.

(FR) Veuillez suivre la sequence du Worflow 1, 2, 3 ...comme vous pouvez le voir sur le schema.

(EN) Pls follow the sequence of the workflow 1,2,3,... as you can see on the draft.